

CHROMATECH, lowest thermal elongation, can withstand highest temperatures, yet still provide optimum production methods.

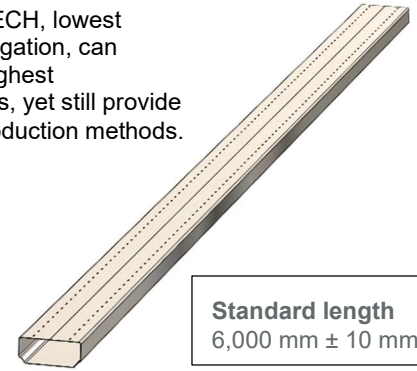

Standard length
6,000 mm ± 10 mm

DIMENSIONS

Sizes	B [mm] +/- 0.10
CHROMATECH 8	7.5
CHROMATECH 10	9.5
CHROMATECH 11	10.5
CHROMATECH 12	11.5
CHROMATECH 13	12.5
CHROMATECH 14	13.5
CHROMATECH 15	14.5
CHROMATECH 16	15.5
CHROMATECH 18	17.5
CHROMATECH 20	19.5
CHROMATECH 24	23.5

H = 6.50 +/- 0.10 mm, H2 = 5.00 +/- 0.10 mm

C = Centre height measured at the welding is H + 0.05 – 0.15 mm. Due to better bending quality

MATERIALS

Stainless Steel The wall thickness is standard 0.18 mm

ACCESSORIES

Connectors



Plastic/Nylon



Steel

Corner

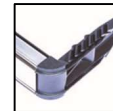

Plastic/Nylon



Steel

Other accessories as flexible corners etc. are also available

COLORS

Can be supplied in almost all RAL and NCS colors.

EN1279 Normative test references and other methods



Pull force
Depends on chosen connector



Compression data (16 mm spacer)
Max. 30 N/cm static pressure



Rectitude from production
Sideways max. 5 mm/m
Up/down max. 10 mm/m

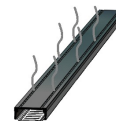

Volatile elements / Fogging test
EN 1279
 $M_v < 0.05\%$ / No fogging



Two box model characteristic value
IFT WA-17/1
 $\lambda_{eq,2B} = 0.81$ W/mK



Thermal linear expansion
 $T_{\alpha,metal}$ 16 mm spacer = 1.5×10^{-5} 1/K



Perforation holes size
Checked with airflow
Allowed humidity uptake 1-5wt% pr. 24 hours

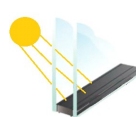

UV stability (painted finish)
EN ISO 4892-2 / A
3,000 hours of radiation with no significant color change

QUALITY ASPECTS

Quality management

EN ISO 9001 for quality and ISO 50001 for Energy Management Systems.

Tests of the product

Processes and routines are established to secure the quality of the delivered material. During production the spacers are continuously monitored through systematic and random checks. Data will be available for a period of 10 years.

Full filing external demands according to:

- EN 1279
- Passive House Component Class pHC for warm, temperate climate
- RAL gütezeichen

CUSTOMER FOCUS AND WARRANTY

On all spacers we offer a 5 years' product warranty. The warranty covers free exchange of spacers in case of a defect. The warranty does not cover any other cost than the mere exchange of the defect spacers, and the warranty expressly does not cover installation of the spacers. The spacers must have been stored, installed and used according to present norms and technical standards. Special solutions and **usage that are not standardized** will need prior approval in writing from us in order to be covered. Related to temperature standardized condition for IG is -30°C/+70°C. CHROMATECH handles higher temperature.

Storage and use

To secure the performance of the spacers, the stock conditions must be acceptable. Broken packaging, humidity and variation in temperature will have an effect on the spacer in general. Make sure the spacer is conditioned at room temperature before use.

Preferred conditions will be temperatures over 15°C and humidity RH of minimum 45%. Avoid having an environment with high concentration of dust.

General handling and attention according to safety data sheet for the spacer. Use gloves when handling the spacer/frames and make sure there is exhausting when cutting the spacer.

System performance

The user (the IG producer) must secure the whole system consisting of spacer, connector/corner key, bending machine, desiccant, butyle and sealant works well together in the chosen setup. Focus on compatibility, adhesion, dust and corner quality.

After handling and transport of the frames, it's important to check if the connector/corner keys are still in the correct position, if not there is a significant risk for desiccant dust inside the IG unit. Foam behind the connector/corner can be used to avoid such problems.

It is recommended to investigate and control all the specific points above.

ADDITIONAL SPECIFICATIONS AND INSTRUCTIONS

Packaging, volumes and options

Packaging Sizes	Quantity meter		Quantity pcs. / box			
	Box	Container bundled	Steel (DP*)	Plastic/Nylon (DP*)	Steel corner	Plastic/Nylon corner
8	1,260	14,004	2,500	5,000	5,000	5,000
10	960	12,672	2,500	5,000	5,000	5,000
11	768	10,368	2,500	-	-	-
12	768	10,368	2,500	5,000	2,500	5,000
13	672	9,216	2,500	-	-	-
14	672	9,216	2,500	5,000	2,500	4,000
15	576	8,448	2,500	5,000	2,500	4,000
16	576	8,064	2,000	5,000	2,500	3,500
18	480	7,296	1,500	4,000	2,500	4,000
20	480	6,144	1,500	4,000	2,500	3,000
24	384	5,376	1,500	3,000	2,000	-

Sizes	Content [g/m] Desiccant 0.5-0.9 mm grain	Connector		Corner	
		Steel (DP*)	Plastic/Nylon (DP*)	Steel Corner	Plastic/Nylon Corner
8	31	✓	✓	✓	✓
10	40	✓	✓	✓	✓
11	44	✓			
12	49	✓	✓	✓	✓
13	53	✓			
14	58	✓	✓	✓	✓
15	63	✓	✓	✓	✓
16	68	✓	✓	✓	✓
18	77	✓	✓	✓	✓
20	86	✓	✓	✓	✓
24	104	✓	✓	✓	✓

*DP = Desiccant passage

All connectors are basically U-shaped and with passage for flow of desiccant during after filling.
Notice that preinserted connectors will lose some of its force.

Energy labeling

For thermal calculations, these values are given (according to EN 10077 and EN 10088). Ask for drawing.

Materials	λ [W/mK]
Butyle	0.24
Desiccant	0.10
Secondary sealing	0.40
Stainless steel (At 20°C)	15

Thermal data

An overview of thermal data with different constructions. These data are calculated by Bauwerk according to IFT guideline WA-08/3.

Frame: Aluminum profile – $U_f = 1.6 \text{ W/m}^2\text{K}$

Glass	Double IG - $U_g = 1.1 \text{ W/m}^2\text{K}$ (4-16-4)			Tripple IG - $U_g = 0.7 \text{ W/m}^2\text{K}$ (4-12-4-12-4)		
	Ψ_g [W/mK]	$\Theta_{\text{sil}(-10/-5 \text{ °C})}$	U_w [W/m ² K]	Ψ_g [W/mK]	$\Theta_{\text{sil}(-10/-5 \text{ °C})}$	U_w [W/m ² K]
CHROMATECH	0.068	8.4 / 10.3	1.439	0.066	10.6 / 12.2	1.174
CHROMATECH plus	0.064	8.7 / 10.3	1.429	0.060	10.9 / 12.4	1.159
MULTITECH A	0.059	9.2 / 11.0	1.417	0.055	11.4 / 12.8	1.147
CHROMATECH ultra S	0.050	9.8 / 11.5	1.395	0.046	12.0 / 13.3	1.126
THERMIX TX Pro	0.049	9.8 / 11.5	1.393	0.044	12.0 / 13.3	1.121
CHROMATECH ultra F	0.048	9.9 / 11.6	1.390	0.043	12.1 / 13.4	1.118
MULTITECH G	0.035	10.9 / 12.4	1.359	0.030	13.0 / 14.2	1.087

Frame: PVC profile – $U_f = 1.2 \text{ W/m}^2\text{K}$

Glass	Double IG - $U_g = 1.1 \text{ W/m}^2\text{K}$ (4-16-4)			Tripple IG - $U_g = 0.7 \text{ W/m}^2\text{K}$ (4-12-4-12-4)		
	Ψ_g [W/mK]	$\Theta_{\text{sil}(-10/-5 \text{ °C})}$	U_w [W/m ² K]	Ψ_g [W/mK]	$\Theta_{\text{sil}(-10/-5 \text{ °C})}$	U_w [W/m ² K]
CHROMATECH	0.051	8.3 / 10.3	1.257	0.050	9.9 / 11.6	0.982
CHROMATECH plus	0.049	8.5 / 10.3	1.253	0.048	10.1 / 11.8	0.977
MULTITECH A	0.045	9.0 / 10.8	1.243	0.043	10.6 / 12.2	0.965
CHROMATECH ultra S	0.040	9.5 / 11.3	1.230	0.038	11.1 / 12.6	0.953
THERMIX TX Pro	0.040	9.5 / 11.3	1.230	0.038	11.1 / 12.6	0.953
CHROMATECH ultra F	0.039	9.6 / 11.3	1.228	0.037	11.2 / 12.7	0.950
MULTITECH G	0.031	10.5 / 12.1	1.218	0.029	12.1 / 13.4	0.931

Frame: Wood profile – $U_f = 1.4 \text{ W/m}^2\text{K}$

Glass	Double IG - $U_g = 1.1 \text{ W/m}^2\text{K}$ (4-16-4)			Tripple IG - $U_g = 0.7 \text{ W/m}^2\text{K}$ (4-12-4-12-4)		
	Ψ_g [W/mK]	$\Theta_{\text{sil}(-10/-5 \text{ °C})}$	U_w [W/m ² K]	Ψ_g [W/mK]	$\Theta_{\text{sil}(-10/-5 \text{ °C})}$	U_w [W/m ² K]
CHROMATECH	0.053	7.3 / 9.4	1.322	0.054	9.6 / 11.3	1.045
CHROMATECH plus	0.051	7.6 / 9.7	1.317	0.051	9.9 / 11.6	1.038
MULTITECH A	0.047	8.0 / 10.0	1.307	0.047	10.4 / 12.0	1.028
CHROMATECH ultra S	0.041	8.6 / 10.5	1.293	0.040	11.0 / 12.5	1.010
THERMIX TX Pro	0.040	8.7 / 10.6	1.290	0.039	11.0 / 12.5	1.008
CHROMATECH ultra F	0.039	8.8 / 10.7	1.288	0.038	11.2 / 12.7	1.005
MULTITECH G	0.030	9.8 / 11.5	1.265	0.028	12.2 / 13.5	0.980

Frame: Wood aluminum profile – $U_f = 1.4 \text{ W/m}^2\text{K}$

Glass	Double IG - $U_g = 1.1 \text{ W/m}^2\text{K}$ (4-16-4)			Tripple IG - $U_g = 0.7 \text{ W/m}^2\text{K}$ (4-12-4-12-4)		
	Ψ_g [W/mK]	$\Theta_{\text{sil}(-10/-5 \text{ °C})}$	U_w [W/m ² K]	Ψ_g [W/mK]	$\Theta_{\text{sil}(-10/-5 \text{ °C})}$	U_w [W/m ² K]
CHROMATECH	0.059	6.1 / 8.4	1.342	0.060	8.7 / 10.6	1.075
CHROMATECH plus	0.056	6.4 / 8.7	1.335	0.056	9.0 / 10.8	1.065
MULTITECH A	0.051	6.9 / 9.1	1.323	0.051	9.5 / 11.3	1.053
CHROMATECH ultra S	0.045	7.6 / 9.7	1.308	0.043	10.2 / 11.8	1.033
THERMIX TX Pro	0.043	7.6 / 9.7	1.303	0.042	10.3 / 11.9	1.031
CHROMATECH ultra F	0.043	7.8 / 9.8	1.303	0.041	10.4 / 12.0	1.028
MULTITECH G	0.031	8.9 / 10.8	1.274	0.029	11.5 / 12.9	0.999

Θ Internal glass temperature

To calculate with other U-values for glass please refer to our homepage where a calculator can be found (<https://www.winuw.de/rolltech/>). Is also available as an app "WinUw ROLLTECH". Access it by Apple store or on Google play.

Adhesion check

According to EN1279-6 D.2 the following test must be done in order to check mixing and secure the adhesion between spacer and sealant. A pull of 0.3 MPa shall be applied for 10 minutes. No adhesive breakage is allowed (slip to surface).

The following is a guide to achieve the correct results for our spacers. The sealant shall cover 20 mm of the spacer back as shown on the drawing. No precleaning of spacer is allowed. It is important to secure a proper contact between sealant and spacer back. The support from the test machine shall be as close as possible to the sealant and direct to the spacer back as illustrated.

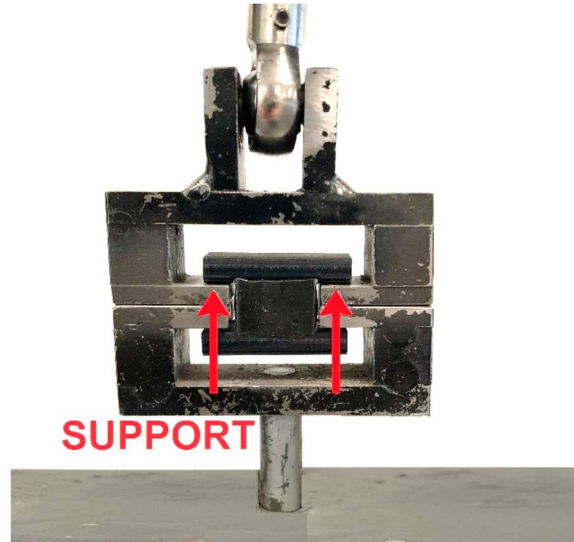
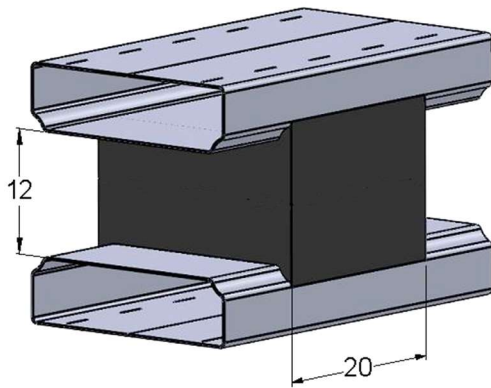

Ask actual sealant supplier for the conditions required during curing. Here some general guidelines:

- For PS curing at 20°C over a period of 24 to 48 hours is normally enough.
- For PU curing at 20°C can take much longer depending on the PU version. 28 days or more is quite normal. Ask sealant supplier for guidelines, it might be possible to accelerate the curing at a higher temperature.

Check the samples for type of breakage. Adhesive breakage is not allowed, and if seen analyzing is needed. Sources to failure: Wrong mix of sealant (A+B), insufficient application, contamination, or deformation of spacers.

Bending

- Use bending tools recommended by bending machine supplier
- Adjust side pressure until correct corner width is obtained (max +0.3 mm)
- Over bending due to resilience is to be adjusted for perfect 90° corners
- Cut with stainless steel saw blade or abrasive wheel
- Room temperature during processing > 15°C

For further bending instructions, contact your bending machine supplier.

Saw blades and saws

Use tools suitable for cutting and drilling stainless steel. A saw blade for aluminum and steel can't be used for stainless steel. Contact supplier of machines/saws first to be advised for the best possible fit to the spacer bar or alternatively ask your spacer supplier for support in case of not finding suitable solutions. Make sure all particles and dust are removed.

IMPORTANT:

It is essential that the spacer is fixed during sawing and without vibrations – if not – the lifetime of the blade/wheel will be shortened dramatically.